

7) Insert Tow Rope Through 5/16" Holes drilled in front of sled and tie knots on inside to secure.

8) ASSEMBLE COVER TO FRAMES.

Set up Frames A, B and C as shown in Fig. 8 and **Lock Folding Braces**. **NOTE:** Frame D will be laying on sled lip. Place Cover over frames with Skirt end at Frame A and adjust cover and frames so that the Velcro loops sewn into cover are near frames. Reach under Cover from Frame D end and wrap Velcro around Frame C, then Frame D. Reach under Cover from Frame A end and wrap Velcro around Frame B. Lift Frame A up and wrap Velcro at Skirt around Frame A. Adjust cover so that it is centered side to side on frames...use seams as a guide.

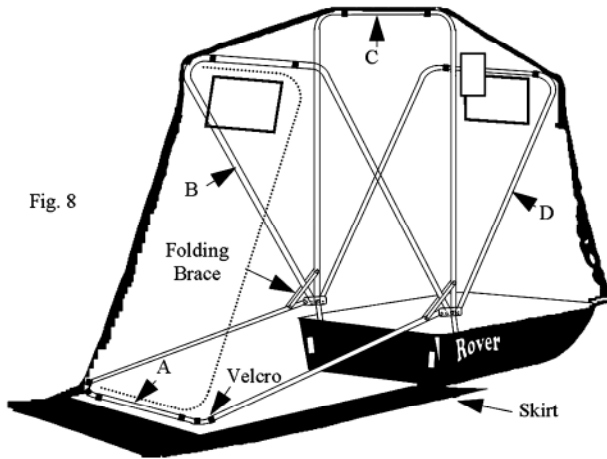

9) ATTACH COVER WITH TRIM.

With Shelter set up as in Fig. 8, pull cover down around sled lip to remove slack, but not so much that you lift frame A off the ground. **NOTE:** you may want to put some weight on frame A to hold it to the ground. Fold excess material under lip of sled and temporarily attach clothes pins near corners. The seams of the Cover should be equally spaced from the corners of the sled. Starting at one side and working around to the other side, attach cover by pushing trim over fabric and lip of sled as shown in Fig. 9, **DO NOT PULL DOWN ON COVER WHEN PUSHING ON TRIM**, it is better for cover to be a little loose than tight. Cut off extra Trim. Black Trim Screws are provided to help secure trim. Equally space screws around sled as shown in Fig. 10. Drill holes for trim screws with a #38 or 3/32" drill bit.

NOTE: Velcro Tabs on back sled wall are provided to attach skirt of cover to sled. This helps to reduce movement of skirt in the wind.

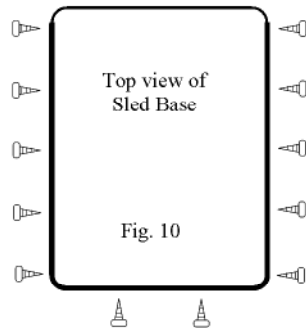
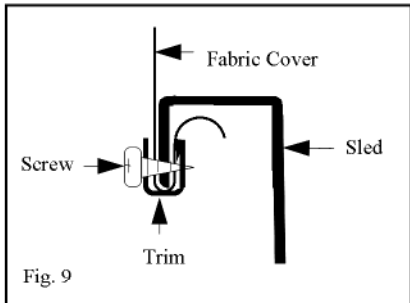

Shappell

Rover[®] 1.0

Model: RV1

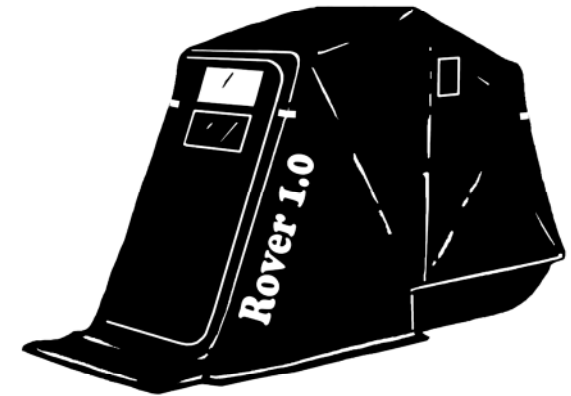

IMPORTANT SAFETY INFORMATION

WARNING: Keep all Heat & Flame Sources away from the Shelters Fabric Cover. The Fabric Cover is Fire Retardant, it is not Fire Proof. The use of any heat source can be extremely dangerous, both for Fire Hazard and Carbon Monoxide Emissions. The Shappell Corporation does not endorse the use of any Heater. It is the users responsibility to follow the Instructions and Warnings provided by the Heater Manufacturer for the safe use of a particular Heater.

CARBON MONOXIDE POISONING HAZARD: This shelter is nearly air tight and must be ventilated if using any oxygen consuming heat source. **DO NOT PACK SNOW AROUND SHELTER** or in any way prevent fresh air from entering shelter. **Failure to Ventilate Shelter could create a Serious Health Hazard or Death.**

PARTS LIST

HARDWARE BAG

Item	Description	Qty.	Item	Description	Qty.
			8.	Tow Rope	1
			9.	Frame Riser Tube	2
1.	Sled Base	1	10.	1/4-20 x 2-1/4" Hex Bolt	6
2.	Seat	1	11.	5/16" Hex Nut	2
3.	Shelf	1	12.	5/16" x 7/8" Long Hex Nut	2
4.	Frame Assembly	1	13.	1/4-20 Nut w/ nylon insert	6
5.	Seat Rails	2	14.	2" Fender Washer	4
6.	Trim	1	15.	1" Fender Washer	8
7.	Cover	1	16.	Shelf Bracket	2
			17.	#6 x 1/2" Black Trim Screws	12
			18.	#10 x 5/8" Screws	6

Shappell Corporation 3562 W. Jefferson, Grand Ledge, MI 48837
517-622-2700 888-571-1144 Fax: 517-622-1435

One Year Warranty

Assembly Instructions

Tools Required: Two 7/16" Wrenches, #2 Philips Screwdriver, 4 clothes pins.

- 1) Loosely assemble (finger tight) Frame Riser Tubes and Seat Rails at rear of Sled Base as shown in Fig. 1 and Fig. 2.

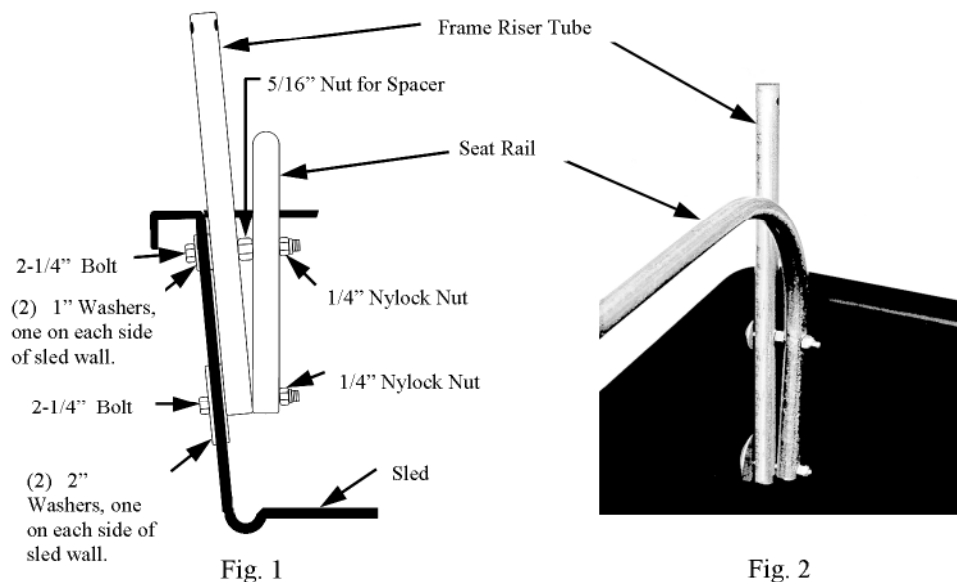

- 2) Push Seat Rails together and slide Seat onto Seat Rails as shown in Fig. 3.

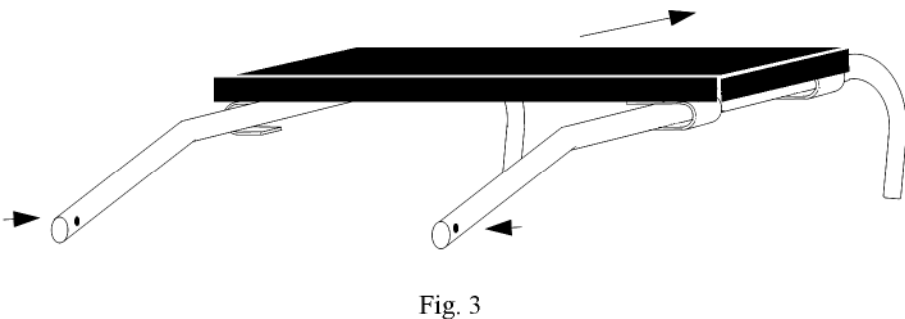

- 3) Loosely assemble (finger tight) Seat Rails at the front of the sled (curved end) as shown in Fig. 4 and Fig. 5.

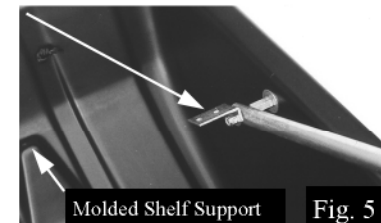
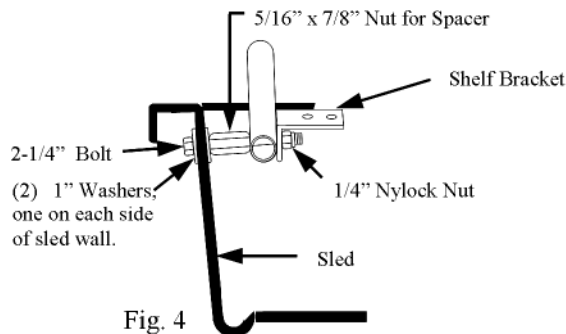

- 4) Attach the Frame Assembly to the outside of the Frame Risers by removing 1/4" Nylock Nuts from the 2-1/2" Pivot Bolts and **threading** bolts through holes in Frame Riser Tubes with the (2) 5/16" nuts between Frame Assembly and Frame Riser Tube for spacers, as shown in Fig. 6, then reinstall 1/4" Nylock Nuts. Leave the Bolts a little loose so they can pivot easily.

CAUTION
When frame assembly is installed correctly there should be (2) frame tubes above the pivot bolt and (1) frame tube below the pivot bolt as shown in Fig. 6.

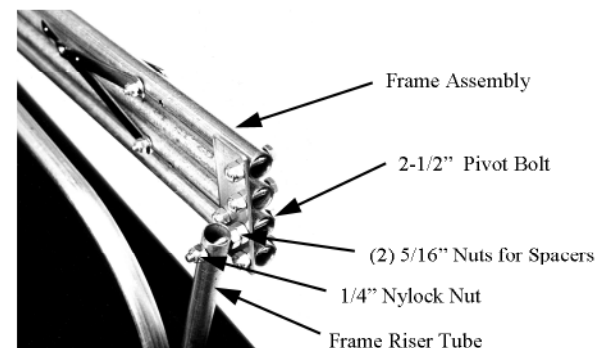

- 5) Tighten the Nuts at the Bottom of the Frame Riser Tubes...**Do Not Overtighten** as you may crush the tubing, then Tighten the Top Nuts and finally the Nuts with the Shelf Brackets.
- 6) Lay the Shelf into the sled with the narrow end resting on the molded shelf supports (Fig. 5) and the wide end on the shelf brackets. Attach the Shelf with (6) #10 x 5/8" Screws as shown in Fig. 7.

